

A complete range of tying machines for the timber Industry.
Suitable as a standalone machine or as an add-on in combination to a cross cutter. The versatility
of our bundling machine knows no limits, round or cornered bundles, soft or hard packages.



VENEER BUNDLING





VENEER-BUNDLING MACHINES

TECHNICAL DETAILS AND SPECIFICATION

Model T 90F

Automatic Tying Machine
to bundle veneer
Max. bundle size 900 x 230 mm
30 cycles/min

Model T 90 VA

Fully automatic tying machine
including infeed and outfeed
conveyors, pneumatic pressing-
unit, photocells, PLC- controlled,
Max. bundle size 900 x 150 mm
max. bundle length 4500 mm
5-15 packs/min. depending on
bundle length

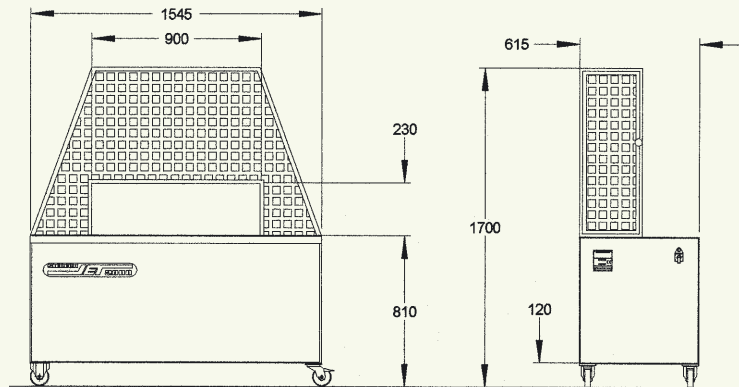

Model T 90F

Model T 120 FS

Similar to Model T 90 F,
but specially designed as an
inline machine in combination
with a clipper, Max. bundle size
1200 x 270 mm, 20 cycles/min

Model T 30

Automatic tying machine for
strip-wood and profiles
Max. bundle size 300 x 240 mm
44 cycles/min. single wrap
35 cycles/min. double wrap

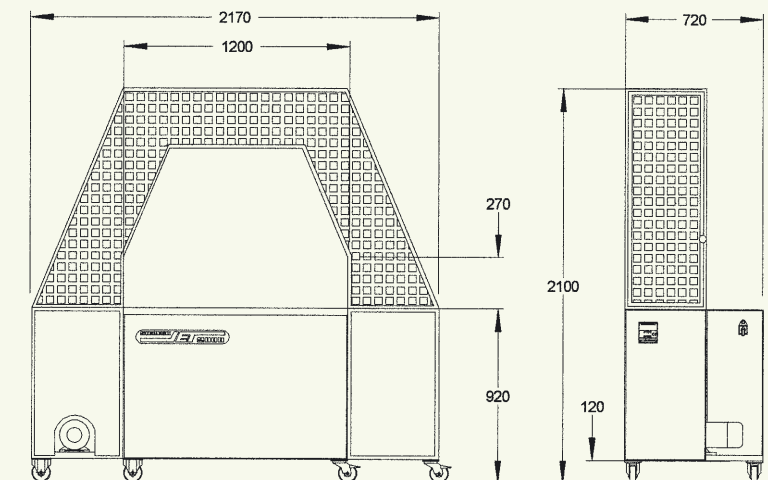

Model T 120 FS

All measurements in mm, specification are subject to change without notice