

Fully Automatic Tying Machine

Standard Features include:

- Non-slip infeed and outfeed conveyors
- Pneumatic grippers for optimum product control
- Vertical side belts to form and hold product
- Interlocked removable catch tray prevents deposits, residues or product -scraps soiling the floor or the inside of the machine
- Tool free belt removal/replacement
- Non-contact product sensors
- Wear-free AC Servomotors
- Automatic reset of knotting unit and ring
- Smart Motion Controller with LED displays
- Up to 60 strings/min
- Selector switch for single, double and triple tying
- Variable belt speed up to 20 mtr/min
- Also available with side knotting unit

Infeed conveyor



Tool free belt removal/replacement

- Encapsulated display module shows:



Number of strings
Desired twine spacing
Belt speed
Self diagnostic error messages
Two level resettable cycle counter

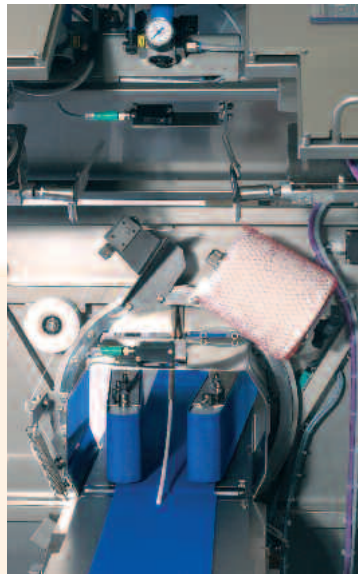

Infeed and outfeed conveyor
Pneumatic grippers
Vertical side belts
Product sensors

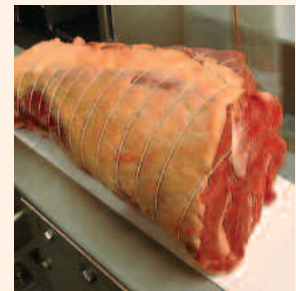

Machine dimensions:

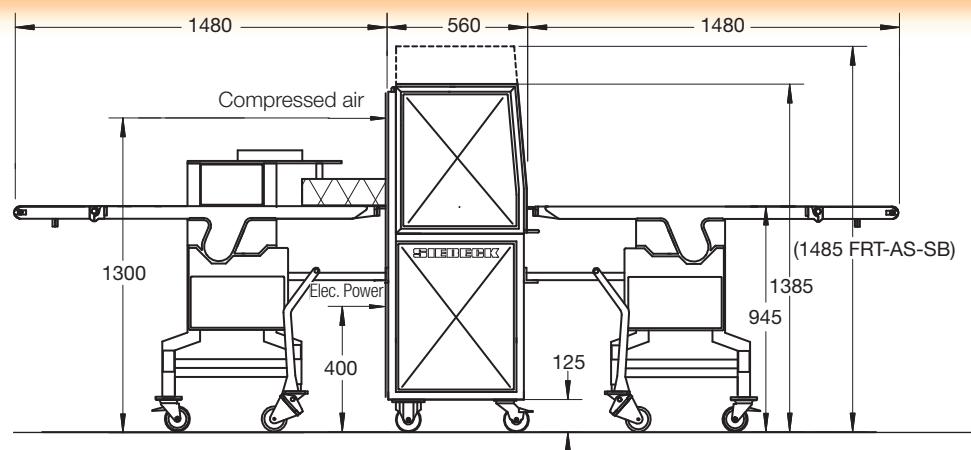

The FRT-A machine offers virtually hands free operation. With amazing speed and consistency, this fully automatic machine is able to transform cuts of meat into attractive case-ready products. Its ease of operation and versatility allows adjustable spacing, number of ties, belt speed along with other features to suit your tying preferences.

FRT-A-SB FRT-AS-SB

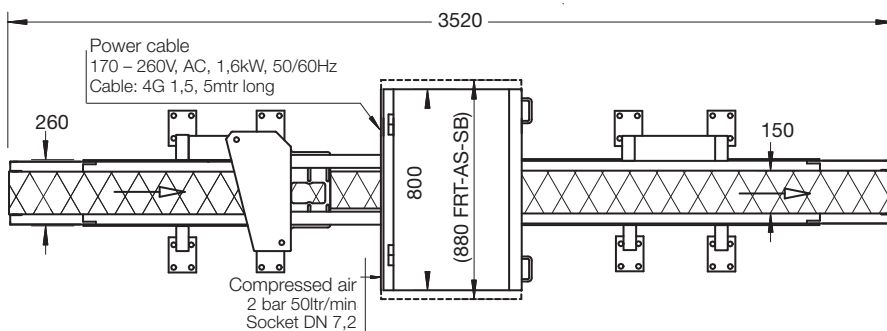

Specifications

Connected load:
170 - 260 V, AC, 50/60 Hz
1,6 kW

Sound pressure level:
72 dB (A) +/- 2

Compressed air
50 ltr/min, 2 bar

Weight:
340 Kg